



# SBF -3920Series

Low Ohmic EB Welded SMD Precision Resistor

### Features

- 12 Watts Permanent Power (0.2mΩ)
- Constant Current up to 245 amps (0.2mΩ)
- High Conductivity Copper Connectors
- Excellent Long Term Stability
- High Application Temperature Range -65°C to +170°C
- Max. Solder Temperature up to 350°C / 30Sec
- Flame Resistant
- Solid Metal Construction
- RoHS and REACH Certified
- AEC-Q200 Compliant

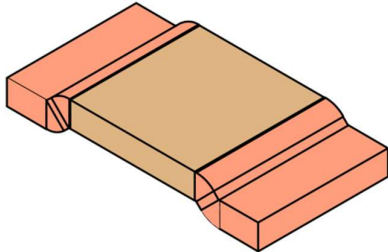

### Applications

- Current Sensing / Feedback
- Automotive Applications
- Power Modules
- Frequency Convertors
- Inverters
- Low Inductance Applications



Technical Data		
Resistance Values	0.1,0.2, 0.3,0.4, 0.5, 0.7, 1, 1.5, 2, 2.5, 3, 4, 5	(mΩ)
Tolerance	1, 5	(%)
TCR - Temperature Coefficient (Resistive Alloy)	<± 20(Copper Manganese Alloys), < -35 (FeCrAl Alloy)	(ppm/K)
Applicable Temperature Range	-65 to +170	°C
Load Capacity	See Table 2	-
Inductance	<3	nH
Stability Deviation	< 0.5 after 2000 Hours, T <sub>t</sub> * = 100°C	%
	< 1.0 after 2000 Hours, T <sub>t</sub> * = 130°C	%

Table 1

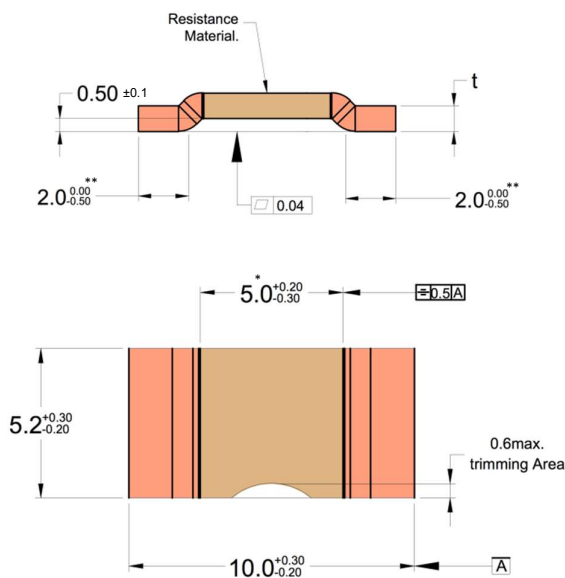

All dimensions are in mm, See table 2 for thickness.  
 \*\* this tolerance(2.0+0, -0.5) applies to t≤0.68 mm, for t>0.68 mm applicable tolerance is 2.0 , +0/-0.8mm and for SBF-CM4-R0001 3.0 +/-0.5mm  
 \* For SBF(S)-CM1-R0002, this dimension is 3.5 + 0.2 , -0.3 and for SBF-CM4-R0001 2.5 +/-0.5mm



# SBF - 3920 Series

Low Ohmic EB Welded SMD Precision Resistor

**Power Derating Curve at 70°C**  
(SBF-CM2-R0005)

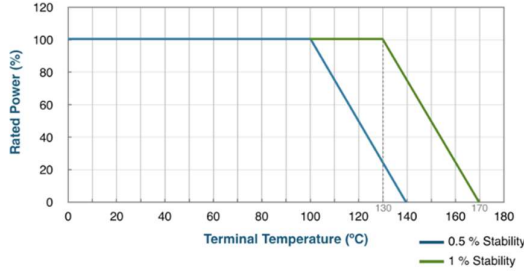

**Typical Resistance Drift ( CM2/CM1 Alloy )**

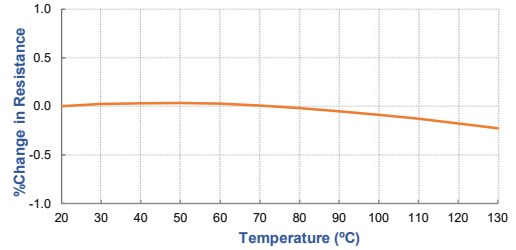

**Typical Resistance Drift ( CM4 Alloy )**

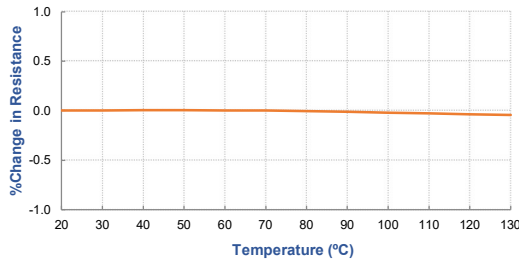

**Typical Resistance Drift ( AC Alloy )**

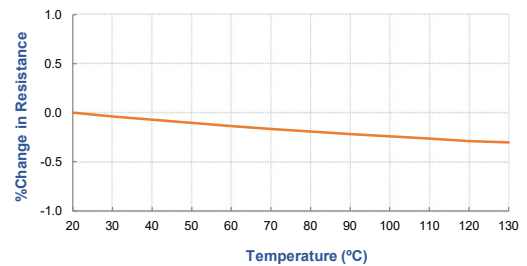

## Performance:

Type of Test	Reference STD	Test Specifications	Acceptance Criteria
High Temperature Exposure	MIL-STD-202 Method 108	1000Hrs. @ T=170°C.Unpowered.	$\Delta R \pm 1\%$
Temperature Cycling	JESD22 Method JA-104	-55°C to 150°C, 1000Cycles, 30Mins at each extreme	$\Delta R \pm 0.5\%$
Biased Humidity	MIL-STD-202 Method 103	85°C & 85RH with 10% operating power, 1000Hrs	$\Delta R \pm 0.5\%$
Operational Life	MIL-STD-202 Method 108	125°C at rated power,1000Hrs	$\Delta R \pm 1\%$
External Visual	MIL-STD-883 Method 2009	Visual inspection	Visual
Physical Dimension	JESD22 Method JB-100	Dimensional inspection as per SBCL Specifications	Shall confirm within tolerance limits
Resistance to Solvents	MIL-STD-202 Method 215	Clean with Aqueous chemical	Marking shall be legible
Mechanical Shock	MIL-STD-202 Method 213	100g for 6ms, Half sine	$\Delta R \pm 0.2\%$
Vibration	MIL-STD-202 Method 204	5g for 20Mins, 12 cycles each of 3 orientations.10-2000Hz	$\Delta R \pm 0.2\%$
Resistance to Soldering Heat	MIL-STD-202 Method 210	Solder Temp. 260°C, Time 10Secs	$\Delta R \pm 0.5\%$
Solderability	J-STD-002	As per J-STD-002	>95% Coverage in 10x Magnification
Electrical Characterization	User Spec.	Resistance as defined	Shall confirm within tolerance limits
Short Time Over Load	--	5x Rated Power for 5Secs	$\Delta R \pm 1\%$
Low Temperature Storage	--	-65°C for 24Hrs	$\Delta R \pm 0.2\%$



# SBF - 3920 Series

Low Ohmic EB Welded SMD Precision Resistor

Type	Resistance Value (mΩ)	Material	t $\pm$ 0.10 (mm)	TCR (ppm)	P <sub>70°C</sub> (W) At Ambient	R <sub>thi</sub> (°C/W)	Wt. (nom.) gm
SBF-CM4-R0001	0.1	Copper Manganese Tin Alloy	1.42	<250	12	2.5	0.65
SBF-CM4-R0002	0.2	Copper Manganese Tin Alloy	1.42	<100	12	2.5	0.65
SBF(S)-CM1-R0002	0.2	Copper Manganese Alloy	1.30	<200	12	2.5	0.60
SBF-CM2-R0003	0.3	Copper Manganese Alloy	1.42	<150	10	3.0	0.65
SBF-CM2-R0004	0.4	Copper Manganese Alloy	1.05	<150	10	7.0	0.48
SBF-CM2-R0005	0.5	Copper Manganese Alloy	0.84	<70	10	7.0	0.39
SBF-CM2-R0007	0.7	Copper Manganese Alloy	0.60	<60	8	8.0	0.28
SBF-CM2-R001	1.0	Copper Manganese Alloy	0.42	< 50	7	10.0	0.19
SBF-AC-R001	1.0	FeCrAl Alloy	1.36	< 50	8	8.0	0.62
SBF-AC-R0015	1.5	FeCrAl Alloy	0.91	< 50	7	10.0	0.42
SBF-AC-R002	2.0	FeCrAl Alloy	0.68	< 50	6	12.0	0.31
SBF-AC-R0025	2.5	FeCrAl Alloy	0.54	< 50	5	13.0	0.25
SBF-AC-R003	3.0	FeCrAl Alloy	0.45	< 50	5	18.0	0.21
SBF-AC-R004	4.0	FeCrAl Alloy	0.34	< 50	5	22.0	0.16
SBF-AC-R005	5.0	FeCrAl Alloy	0.27	< 50	3	30.0	0.12

Table 2

Reel Information	
Reference Standard	DIN EN 60286-3
Width of Reel	16 mm
Reel Diameter (OD)	330mm(13")
Number of parts per Reel	3000 pcs

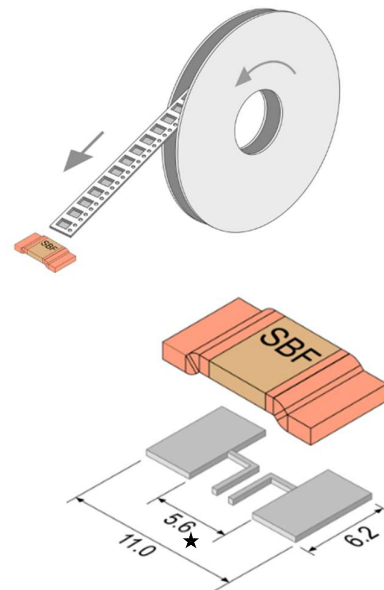
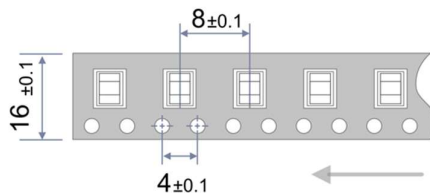

**Note:**

1) Recommended Solder Reflow Profile:

<http://www.shivalikbimetals.com/SRP-01.pdf>

★ For SBF-CM4-R0001 is 3.7mm

**Proposed PCB Layout**



# SBF - 3920 Series

Low Ohmic EB Welded SMD Precision Resistor

### Example of Ordering Code

#### SBF-CM2-R0005-1-TR

